

Ryan Brennan and Jerry Dulude, Glass Expansion Inc., 4 Barlows Landing Road, Unit 2A, Pocasset, MA 02559. rbrennan@geicp.com

Adeeb Rahman, Director of Technology Development, Human Immune Monitoring Core, Icahn School of Medicine at Mt. Sinai, New York, NY 10029. adeeb.rahman@mssm.edu

Noel Casey, Atomic Spectroscopy Consultant, Watertown, MA 02472. noelcasey@gmail.com

Abstract

Analysis of single cells is an important aspect of many disciplines, such as toxicology and medical diagnosis, in addition to drug and cancer research. Due to the ability to simultaneously evaluate large numbers of metal isotopes with high sensitivity and large dynamic range, inductively coupled plasma mass spectrometry (ICP-MS) has become a popular research tool in the fast growing field of high dimensional single cell analysis. Mass cytometry combines ICP-MS with time of flight mass spectrometry (TOF) to determine the properties of a cell. In this technique, antibodies are conjugated with heavy metal ion tags and used to label samples of cells, which can then be analyzed by ICP-MS. The high dimensional analyses offered by mass cytometry permit a detailed evaluation of the phenotypic and functional heterogeneity of cellular samples. However, mass cytometry continues to face challenges in the efficiency of cellular transport to the ICP, which can be particularly problematic when analyzing rare cell populations in limited samples. Our research addresses factors that can affect the condition of the cell prior to introduction to the ICP and ways to improve the efficiency and reliability of sample transport in mass cytometry. A newly designed high efficiency concentric nebulizer with a zero dead volume capillary connection is evaluated in addition to a tool to accurately monitor sample delivery.

MicroMist™ Nebulizer for Single Cell TOF-ICP-MS



A prototype MicroMist nebulizer was evaluated on a CyTOF2 instrument. In contrast to a typical ICP-MS concentric nebulizer, Mass Cytometry requires a very low nebulizer gas flow (≤ 0.3 L/min) and back pressure (≤ 20 psi) to keep the cells intact during nebulization. This posed a major challenge, as with typical ICP nebulizers a low nebulizer gas flow and back pressure will produce a poor aerosol quality resulting in poor transport efficiency (poor sensitivity). Therefore, the prototype MicroMist nebulizer for single-cell analysis required a unique construction to achieve an optimal aerosol quality at a low gas flow to ensure an acceptable cell transmission efficiency.

Nebulizer Design

Glass Expansion is well known for high quality nebulizer designs and precision manufacturing. Unique to all Glass Expansion glass concentric nebulizers is the trademark VitriCone™ sample channel. The VitriCone sample channel (Figure 2) is created by machining constant bore heavy stock glass tubing (Figure 2A) to create the desired aerodynamic exterior (Figure 2B) while maintaining a consistent internal diameter. Other nebulizer manufacturers heat and draw a thin fragile capillary from glass tubing to create the internal capillary. This process often produces a sample capillary with varying inner diameter, an increase in the porosity of the glass, and harmonic vibrations from the flow of argon, all of which degrade performance and lifetime of the nebulizer. A diagram comparing a Glass Expansion nebulizer (Figure 2C) to other manufacturers (Figure 2D) is shown below.

Glass Expansion VitriCone Machined Capillary

Figure 2A. Constant bore heavy stock glass



Figure 2B. Machined aerodynamic exterior



Figure 2C. Glass Expansion VitriCone Machined Capillary

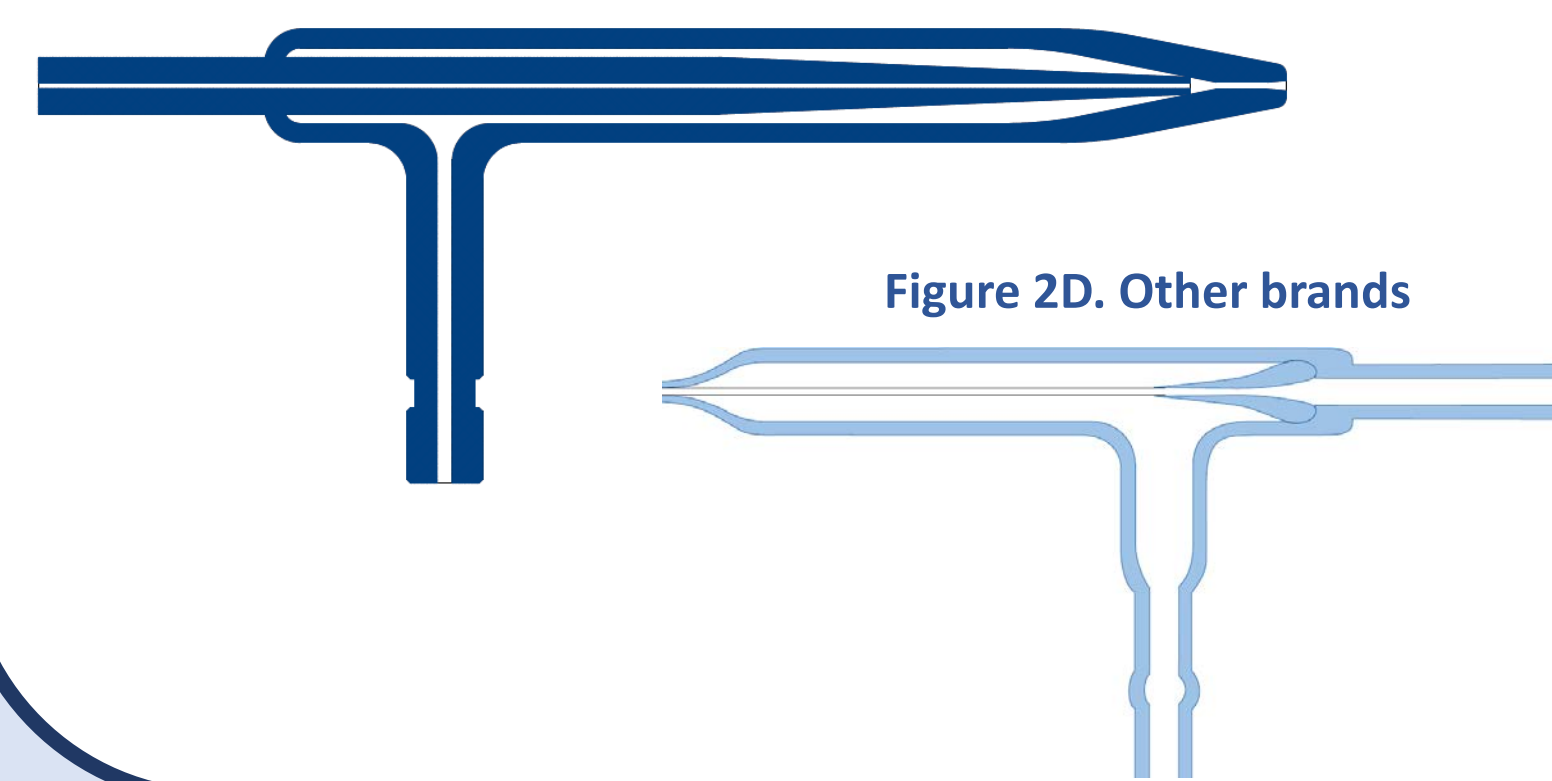

The benefits of the VitriCone construction are:

- The sample channel is guaranteed a constant internal diameter rendering it more resistant to clogging.
- The rugged precision-machined capillary resists vibration producing the best possible analytical precision.
- The industry's tightest tolerances ensure that each nebulizer will perform to the same high standards as the previous one.

Nebulizer Optimization

The gas flow rates for the prototype MicroMist nebulizer were optimized using Tuning Solution (Fluidigm), a high purity solution containing known quantities of defined elements. At a liquid flow rate of 45 μ L/min, the nebulizer gas flow and make-up gas flow of the prototype MicroMist nebulizer optimized at 0.17 L/min and 0.76 L/min, respectively determined using both manual and routine autotuning protocols. These gas flow conditions match those utilized with the standard CyTOF nebulizer and provided an identical signal intensity.

TruFlo Sample Monitor



Part Number	Measurable Flow Rate	Calibrated Flow Rate	Internal Volume	Sample Path
70-803-0892	0 – 0.05 mL/min	0.001 – 0.05 mL/min	0.033 mL	HF Resistant

Single-cell analysis uses a very low uptake of 30-45 μ L/min and maintaining a constant sample flow rate is directly related to the performance of the analysis. Like any ICP application the nebulizer can clog, leaks can occur and the syringe barrel or pneumatic sample holder can degrade, all of which can affect the sample flow rate and analytical performance. Glass Expansion's TruFlo sample monitor, shown above, provides a real-time digital display of the sample flow rate, so you always know the actual flow rate to the nebulizer. This enhances the day-to-day reproducibility of results and reduces the need to repeat measurements.

LC Fittings Kit

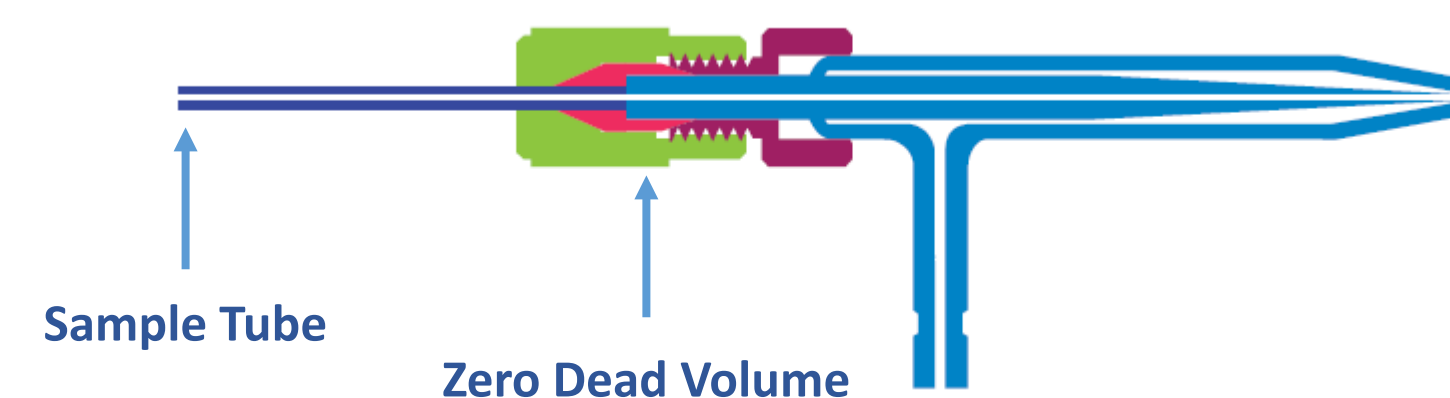

Glass Expansion's MicroMist nebulizer combined with our custom LC Fittings Kit provides an extra advantage for single cell analysis. With the LC Fittings Kit the MicroMist can be quickly and easily directly connected to the syringe or pneumatic driven sample introduction system with a zero dead volume connection.

Results

Using EQ Calibration Beads (Fluidigm), the prototype MicroMist nebulizer showed identical median signal intensity to the standard CyTOF nebulizer.

To test a typical experimental application, the prototype MicroMist nebulizer was used to acquire a stained preparation of peripheral blood mononuclear cells (PBMCs) from a healthy donor. The figure below shows human PBMCs that were stained with a basic immunophenotyping panel and acquired using the standard CyTOF nebulizer and prototype MicroMist nebulizer. The resulting data, visualized using viSNE(15) in Cytobank, show that overall data quality, single cell staining and resolution obtained with the prototype MicroMist nebulizer were identical to the standard CyTOF nebulizer. PBMCs are a powerful tool that can be used to evaluate the immune status of patients and evaluate disease progression and treatment responses.

Stained PBMC

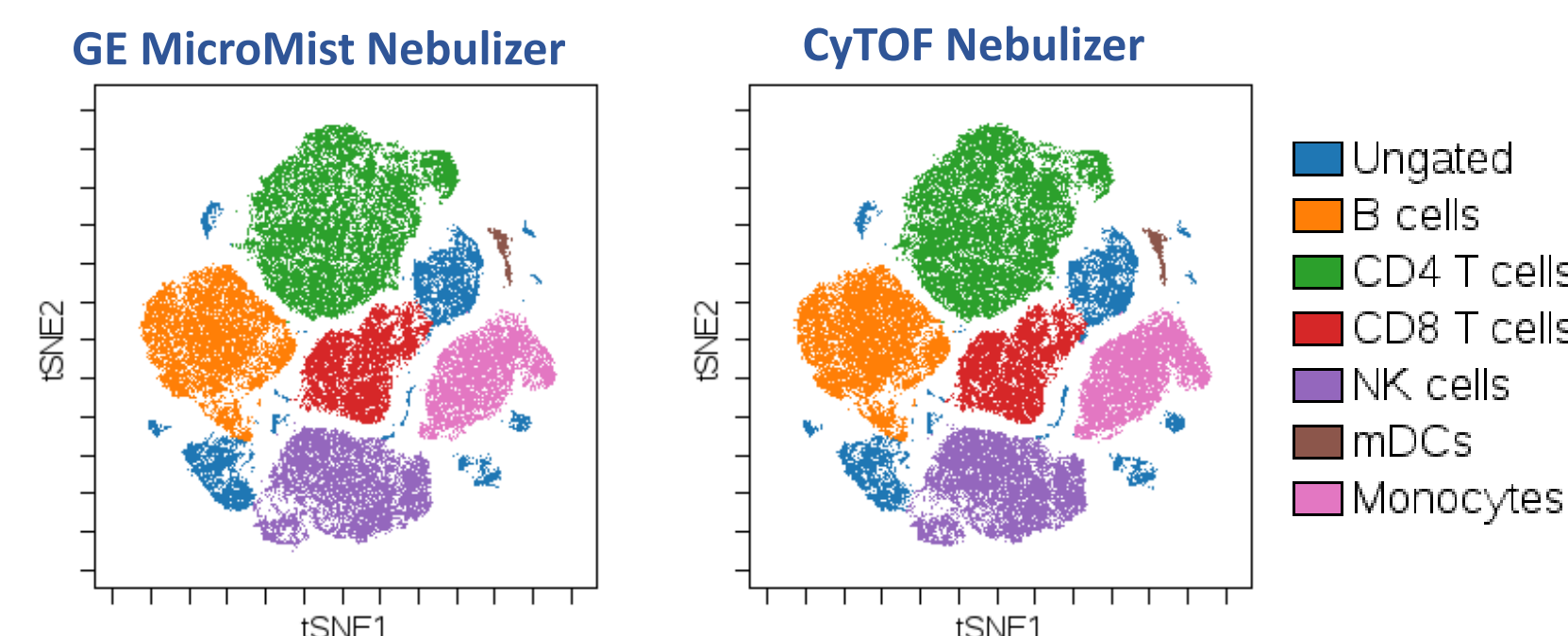

Conclusions

The Glass Expansion prototype MicroMist nebulizer at optimized operating conditions for Mass Cytometry produced excellent data quality and single cell staining. Using a sample flow rate of 45 μ L/min, the prototype MicroMist nebulizer produced a cell transmission efficiency of 33%. The prototype MicroMist nebulizer provides comparable performance to the standard Mass Cytometer nebulizer, but owing to the VitriCone capillary has the advantages of outstanding analytical reproducibility and improved resistance to blockages. The LC fittings kit provided a zero dead volume connection for best sensitivity and low carry-over. Further experiments are planned where the sample flow rate will be varied in the range of 30 to 40 μ L/min to improve cell transmission efficiency. The TruFlo Sample Monitor serves as an essential component to the CyTOF & Helios instruments so that the sample flow rate is continuously and accurately monitored, ensuring the quality of cell transmission efficiency.