

Mastering ICP Coolant Analysis (ASTM) D6130

Steps to Overcome Sample Introduction System (SIS) Challenges



Ryan Brennan, Ph.D.
President

Glass Expansion, Inc.
rbrennan@geicp.com

Biggest Mistake - Not Optimizing your SIS!

This may seem obvious, but the default or standard configuration that your instrument ships with is often not the best for your application.

- “Optimize” can mean many things, so it is important to determine the needs of your system, such as:
 - Maximum sensitivity
 - Improved precision
 - Robustness for “high matrix” samples
 - Minimal carryover
 - Improved washout for high throughput
 - Considerations for low sample volume (e.g., low-flow neb, low-volume spray chamber, etc.)
 - Compatibility with certain acids or solvents
 - The list goes on...

Common Challenges for Coolant Analysis

ASTM D6130:

- **Matrix Effects** - Engine coolants are dense and viscous.
- **Carbon build up** - Continuous aspiration of glycol can result in carbon build up on the torch and injector.
- **Particulates** - Used coolants often contain suspended solids, which can block capillary tubing, switching valves, and nebulizer.
- **Memory Effects** - Silicon is a primary focus of D6130 and known to be a “sticky” element.
- **High Matrix** - Keep high concentration elements within linear range without diluting others below the detection limit.
- **Key Elements** - Si, B, P, K, Na, Mg, and Mo

Coolant Analysis: Solutions

1. Improve Data Quality:

- Select appropriate nebulizer, spray chamber, and torch/injector
- Tailor components to sample type for accuracy, precision & sensitivity

2. Maximize Sample Throughput:

- Address carryover and washout issues to improve efficiency

3. Enhance Performance with Accessories

- Specialized components to reduce re-analysis time and improve data integrity

4. Ensure Longevity & Consistency

- Implement proper care and cleaning routines
- Reduce downtime through preventive maintenance

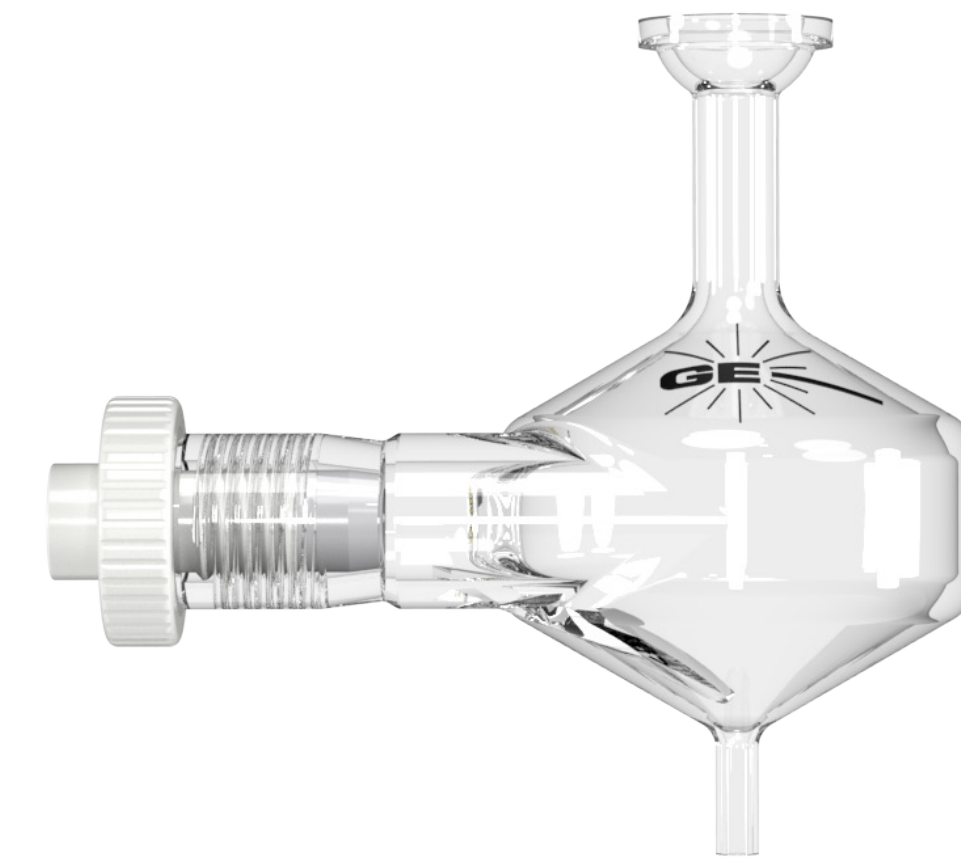

Glass Expansion Nebulizers - Industry leaders

- Glass Expansion is the only manufacturer that takes thick-walled precision-bore tubing and machines the outside to a uniform aerodynamic shape. This guarantees a uniform - lowest-dead-volume sample channel, assuring tolerance to nasty samples and excellent reproducibility.
- No other manufacturer can match the precision and reproducibility of the 'VitriCone' construction, making it the most robust and dimensionally reproducible concentric nebulizer available.
- The Global Standard in Nebulizer Innovation

Manufacturing Tolerance

- A. Controlled overall length precision
- B. Shell Diameter
- C. Full length precision bore capillary
- D. Precision formed jet nozzle
- E. Depth positioning stop

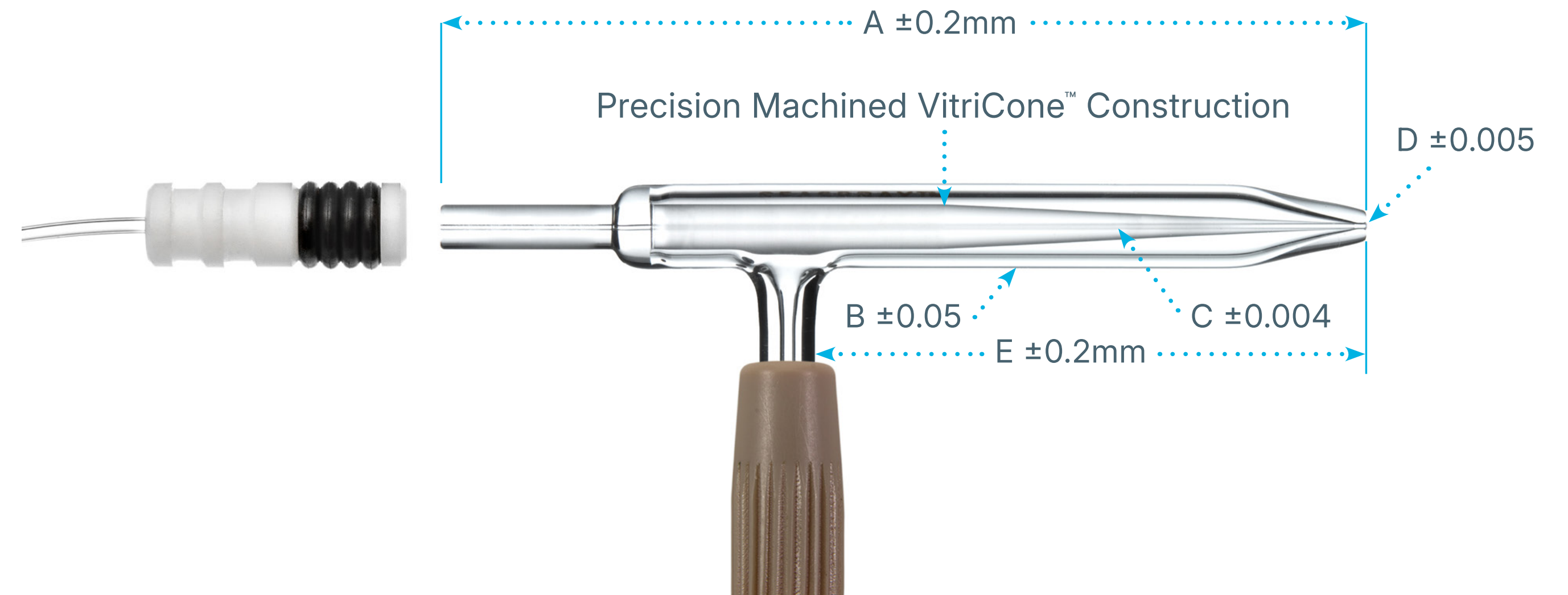

SeaSpray Nebulizer - Outstanding Efficiency and Tolerance to Dissolved Solids

- Material: Borosilicate glass
- A high physical reproducibility (1%) guarantees consistent performance of replacement nebulizers
- TDS tolerance, typically up to 20%
- Tolerance to particulates, typically up to 200µm for USS1 & 2
- Low RSDs due to highly accurate construction
- Lowest dead volume for rapid washout
- Instrument Suitability: used with **both ICP-OES and ICP-MS**

The SeaSpray nebulizer has the highest sensitivity of any concentric glass nebulizer on the market. Perfect for high concentrations of dissolved solids up to 20%TDS.

Common samples include **coolants**, wastewater, seawater, groundwater, surface water, brines, high salt (including Li-ion batteries), soils, sludges and plating baths are just a few examples. A number of ICP-OES instrument manufacturers employ the SeaSpray as part of their standard instrument configuration.



Common standard testing methods include:

- EPA 200.7
- EPA 6010D (SW-846)
- ASTM D1976
- EPA 200.8
- EPA 6020B (SW-846)
- ASTM D5673
- ASTM D6130

Aqueous HP-SIS – Sensitivity Comparison

Sensitivity of Standard Aqueous SIS relative to Glass Expansion Aqueous HP-SIS (relative sensitivity =1)

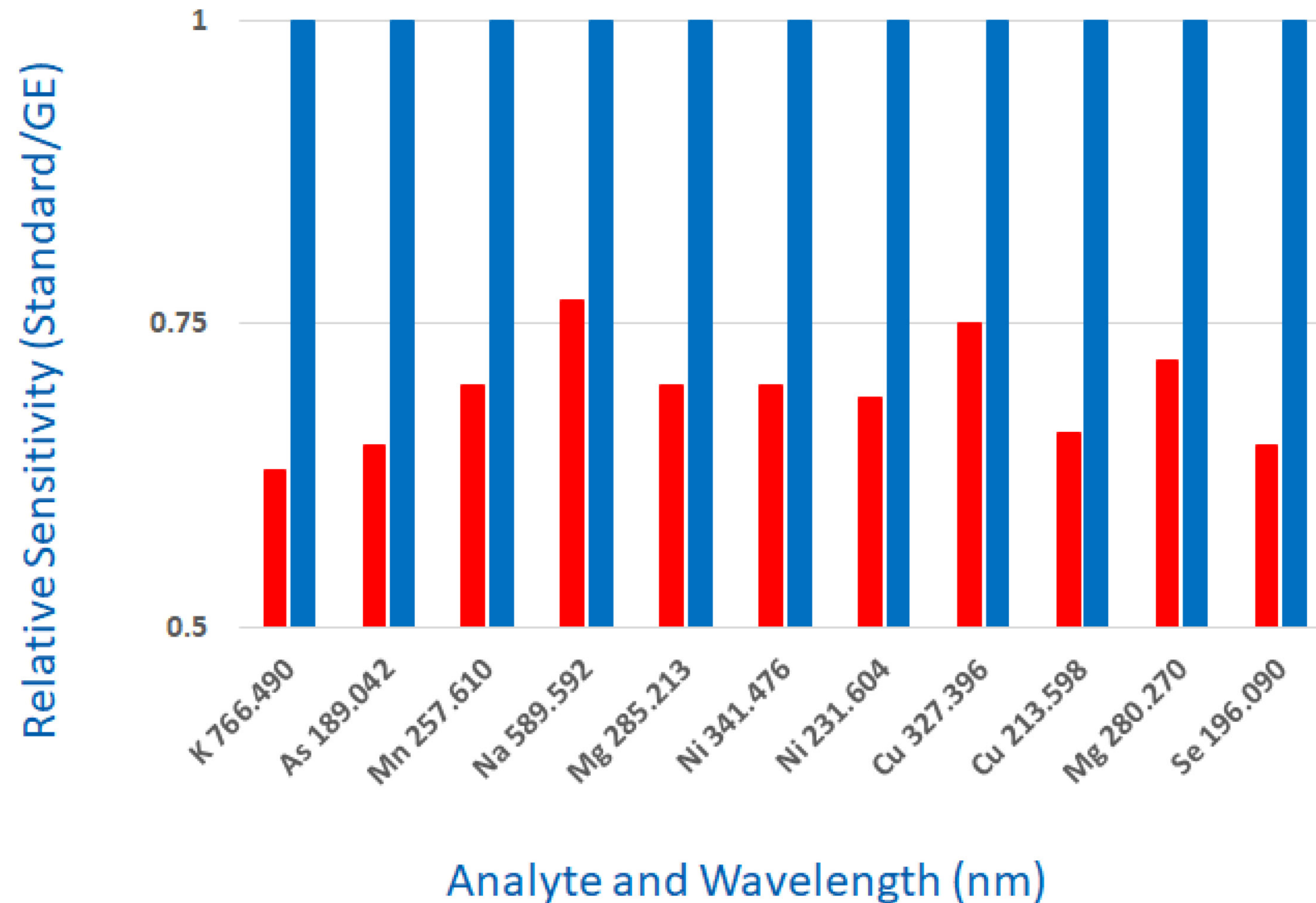

- Glass Expansion Aqueous HP-SIS
 - Average improvement of 30%
- Standard Aqueous SIS



Spray Chambers: Transport Efficiency, Precision, and Washout

What are the common challenges encountered when using spray chambers?

Application Suitability



- HF
- Organics
- Limited volume samples

Transport Efficiency



- Loss of Sensitivity
- Poor Precision and Accuracy
- Inconsistent Signal Stability

Long washout Carryover



- Poor Precision
- Dead volume
- Compromised analytical results

NEW Tracey™ BC Spray Chamber

Features & Benefits:

- 1. No O-Rings:** Reduces washout times and eliminates frequent replacements due to wear.
- 2. Exceptional Precision:** Short-term noise on average 0.5% or better providing excellent repeatability and stability.
- 3. Faster Washout, Higher Productivity:** The advanced 30 mL low-volume cyclonic design with Helix CT™ technology delivers rapid washout and improved sample throughput.
- 4. Wide Compatibility:** Fits most common ICP-OES models.

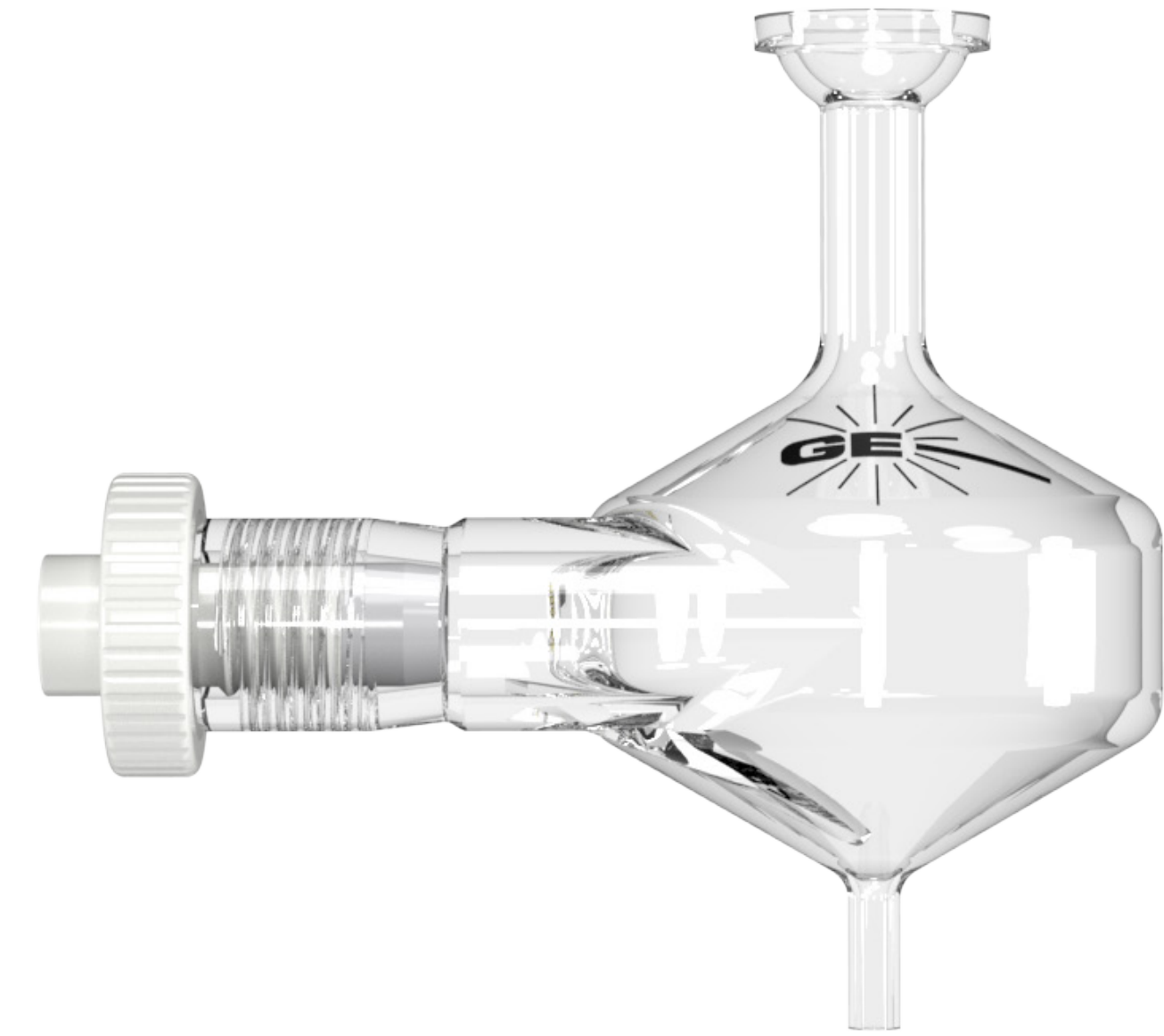

Tracey™ BC Spray Chamber

Tracey™ BC Spray Chambers - Improve Washout

Washout Profiles for 1 ppm Hg:

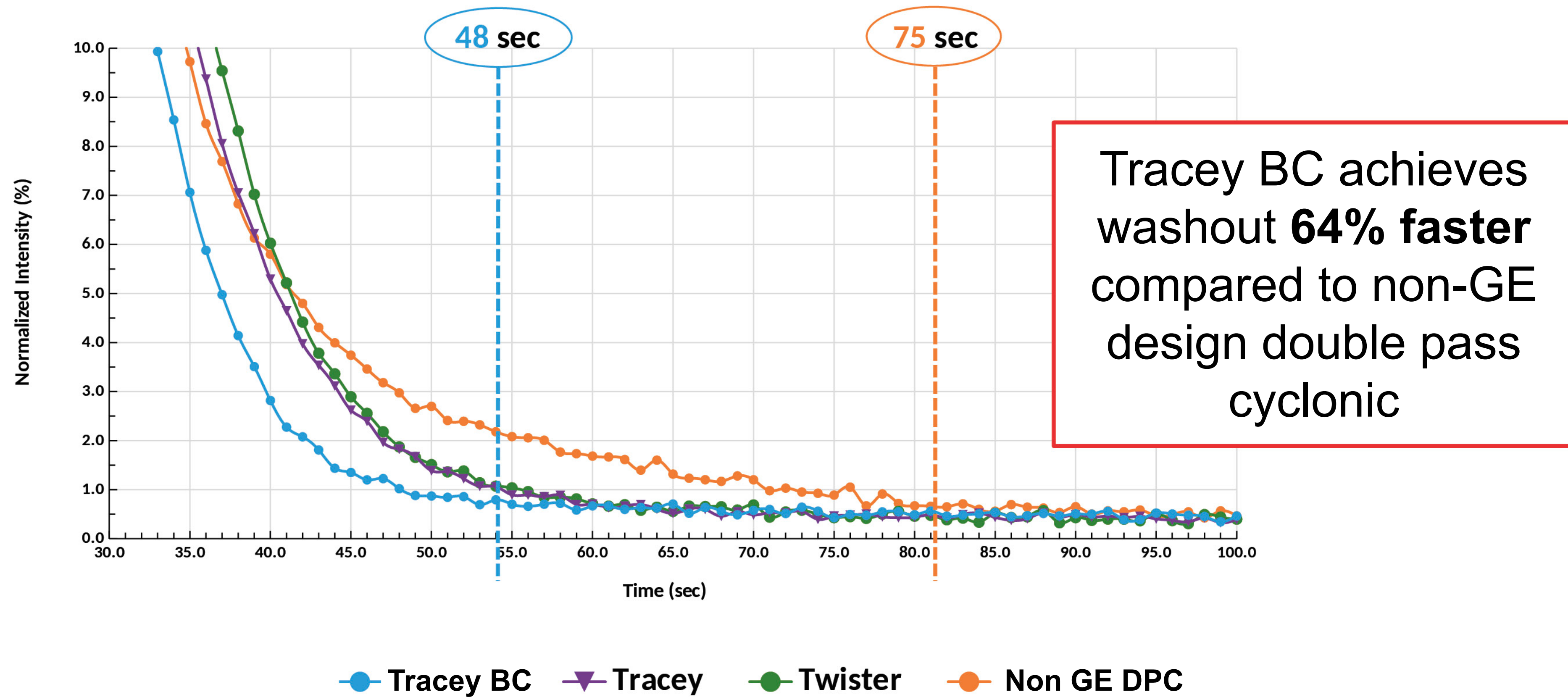

Torch Selection

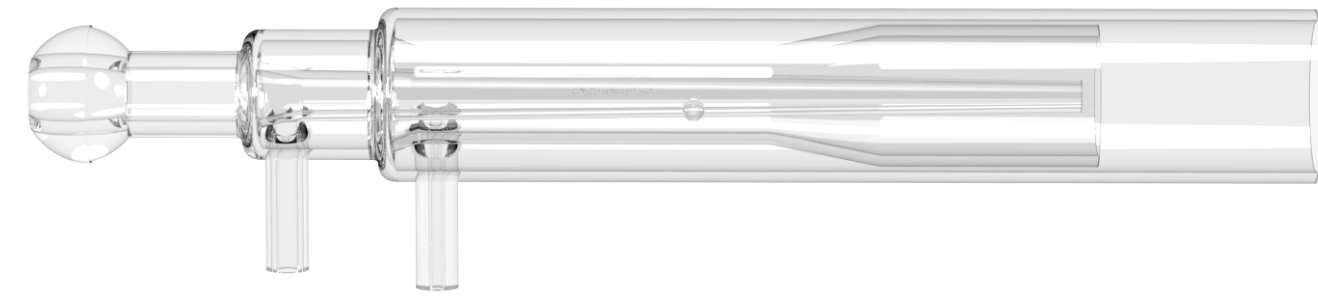

ICP Torch Designs:

1. Single piece quartz torch:

General use torch: Lower initial cost structure with no removable parts



2. Semi-demountable torch:

Enables injector interchangeability without torch replacement and easier maintenance

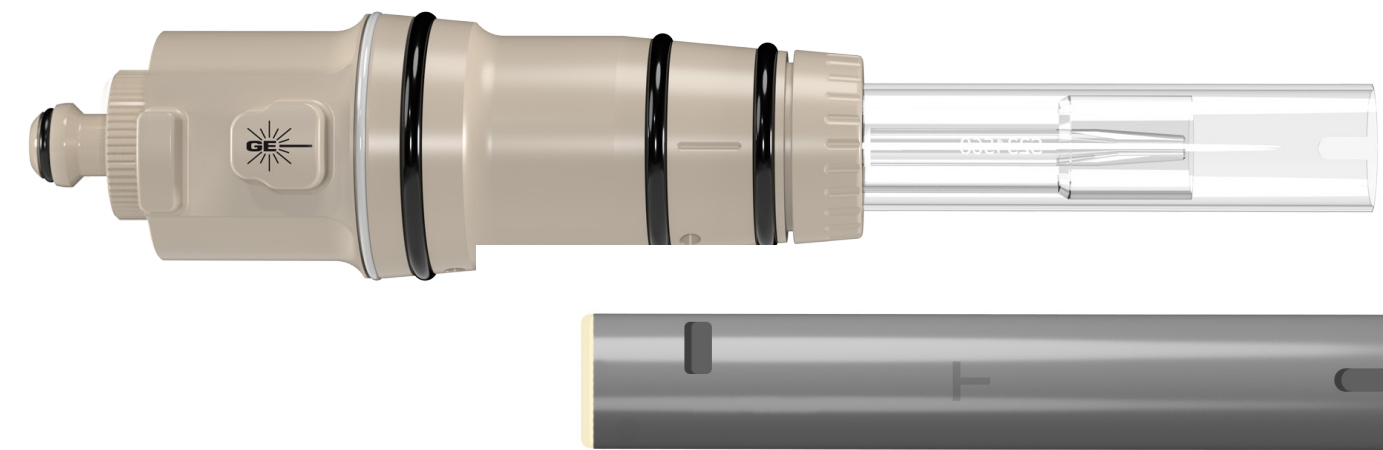

3. E-Torch:

Removable: injector, torch body (optional ceramic)

NEW E-Torch™ for ICP-OES

Benefits

- Made from PEEK, PTFE & Quartz
- Interchangeable injectors (Quartz, Ceramic, Sapphire)
- Ceramic tube set available on request for HF and high TDS applications
- **Our user-friendly plasma tube set and injector retainers maintain precise alignment while simplifying maintenance. Carbon deposits can be easily removed through oven cleaning, reducing service time and maintenance effort.**

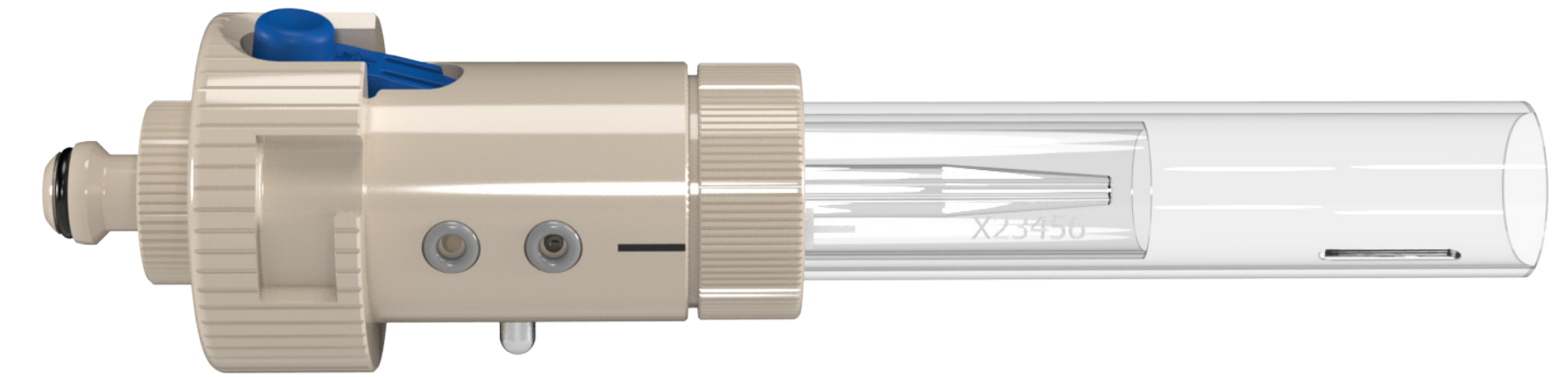

NEW P/N 30-808-4388
E-Torch for Thermo® PRO Duo

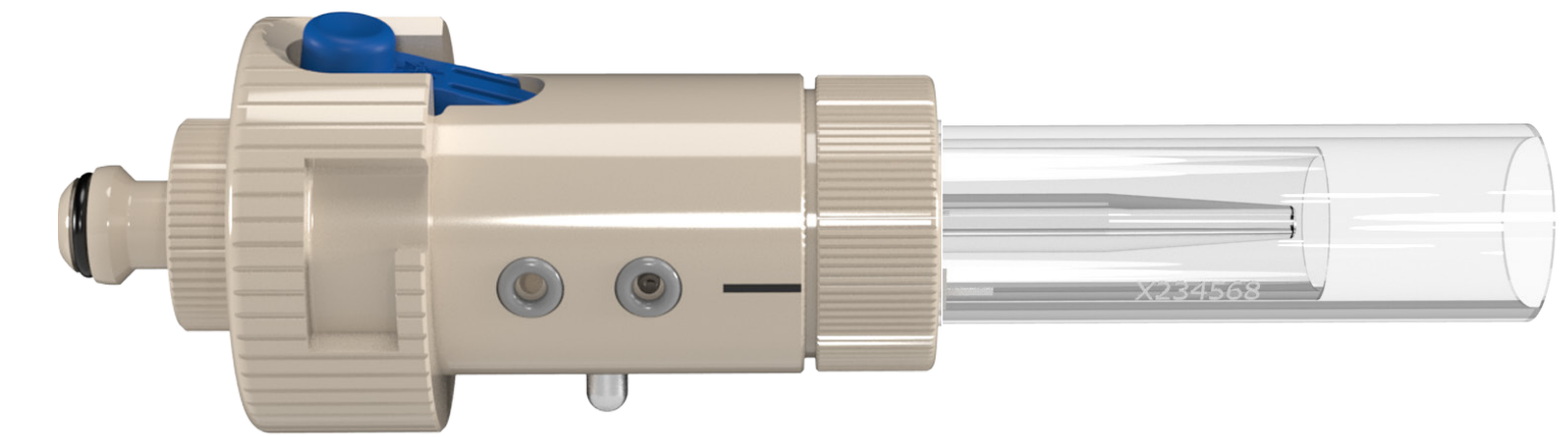

NEW P/N 30-808-5163
E-Torch for Thermo® PRO Radial

S13 Ball Joint Injector Retainer



Quartz Injector 2.0mm

E-Torch Body

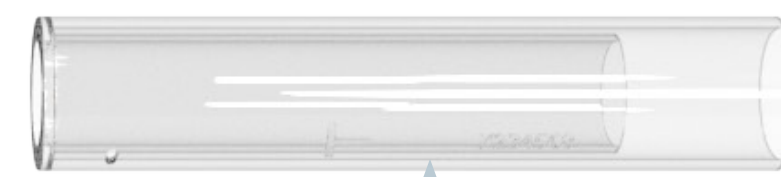
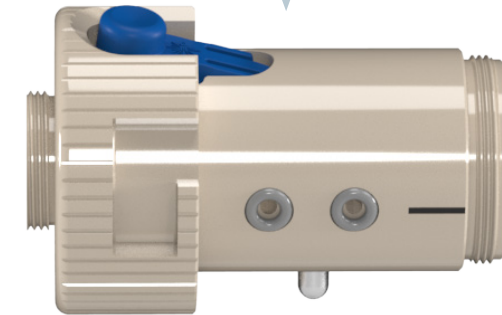

Quartz Plasma Tube Set

E-Torch Tube Set Retainer



Aggressive Sample Matrices: Torch Selection

Examples: Soils, wastewater, brines, high-acid digests, organics, lithium fusions

Challenges:

- High salt deposits and plasma temperatures shorten quartz torch life
- Frequent torch replacement increases cost of ownership

Mitigation:

- Use a Demountable Torch → replace only the outer tube, lowering cost of ownership

Upgrade: Optional all-ceramic plasma tube resists devitrification and thermal shock, providing significantly longer torch life and reduced maintenance intervals.

Benefits: Ideal for high TDS, HF, and organic sample matrices; hotter more robust plasma improves sensitivity.

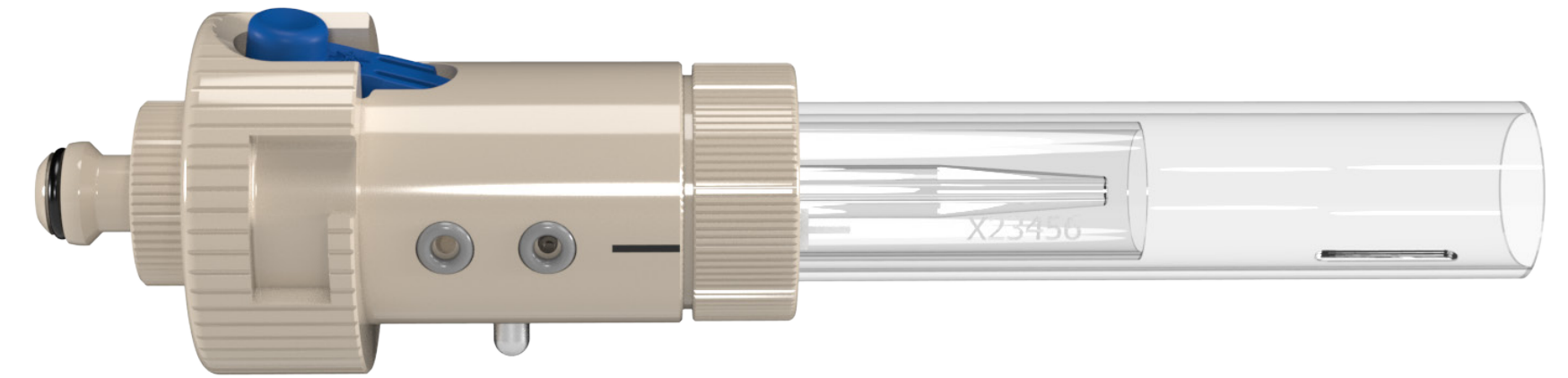

Comparison of Quartz tube set to Ceramic tube set		
Element	% Increase in Sensitivity	%RSD
Zn (213) λ	17%	0.36
Ni (231) λ	19%	0.57
Mn (257) λ	14%	0.52



NEW! Ceramic Plasma Tube Set
P/N 31-808-4502

Guardian™ Autosampler Probe

Features and Benefits:

- **Proprietary mechanical finish** to improve wetting characteristics and prevent the beading of droplets.
- **Robust tip design** prevents crushed or damaged tips from misalignment.
- **Drip-resistant** to minimize cross-contamination.
- **Unique inbuilt particle filtering** prevents blockages in your nebulizer and capillary tubing.
- **Optimized ceramic filter tip** to minimize dripping and particulate blockages.
- **Completely inert construction** (Ceramic, PEEK, and PTFE) for strong acid/solvent resistance.



Guardian Probe Assembly
for ASX-200, 500, 800 Series
P/N 70-803-1787

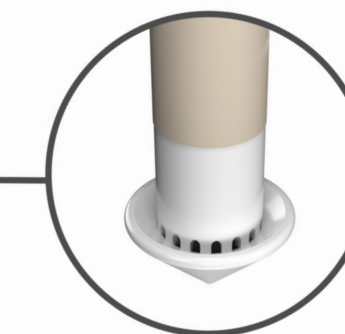

Guardian™ Autosampler Probe

- Interchangeable UniFit™ sample lines IDs: 0.3, 0.50, 0.75 and 1.0mm - Easy and low-cost to replace and maintain clean sample path.

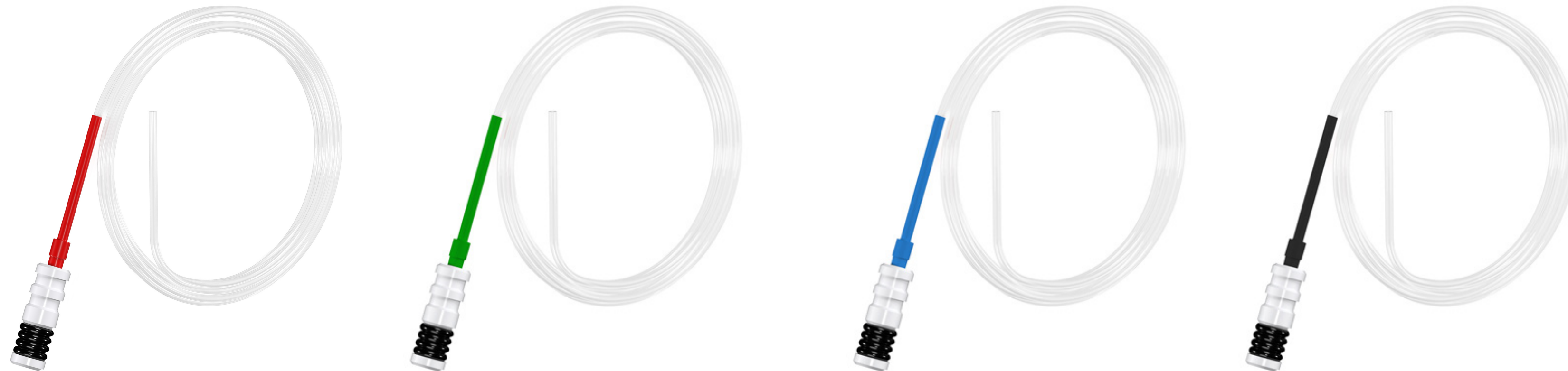

- Color-coded for easy identification and optimization for different applications.
- For use with a high-throughput OEM valve system (high uptake rates), use 1.0 mm.
- For most common ICP-OES applications, choose 0.75 mm.
- For most common ICP-MS applications, choose 0.5 mm.
- For sample flow rates of 0.2 mL/min or lower, 0.3 mm is ideal.

Guardian™ Autosampler Probe

Reduced Re-Analysis Time	Dripping between samples, a common cause of failed calibration curves, is eliminated. Laboratories report reclaiming hours of previously lost instrument time each week.
Fewer Nebulizer Failures	By intercepting particulates before they reach the nebulizer, the Guardian Probe extends service life and significantly reduces unplanned maintenance.
Enhanced Robustness Across Sample Types	From dilute aqueous standards to viscous semi-refined oil matrices, the Guardian Probe performs consistently across all sample campaigns.
Lower Total Cost of Ownership	Fewer nebulizer replacements, less re-analysis, and reduced downtime translate directly to lower operating costs and higher laboratory throughput.
Improved Data Integrity	By preventing cross-contamination and carryover, the Guardian Probe safeguards the integrity of every data point.
Easy Integration	Designed as a direct drop-in replacement on the most popular autosampler platforms — no modifications, no special tools, no downtime for installation.



Summary

1. Improve Data Quality:

- Select appropriate nebulizer, spray chamber and torch/injector
- Tailor components to sample type for accuracy, precision & sensitivity

2. Maximize Sample Throughput:

- Address carryover and washout issues to improve efficiency

3. Enhance Performance with Accessories

- Use tools like Guardian Autosampler Probe to reduce re-analysis time and improve data integrity

4. Ensure Longevity & Consistency

- Implement proper care and cleaning routines
- Reduce downtime through preventive maintenance

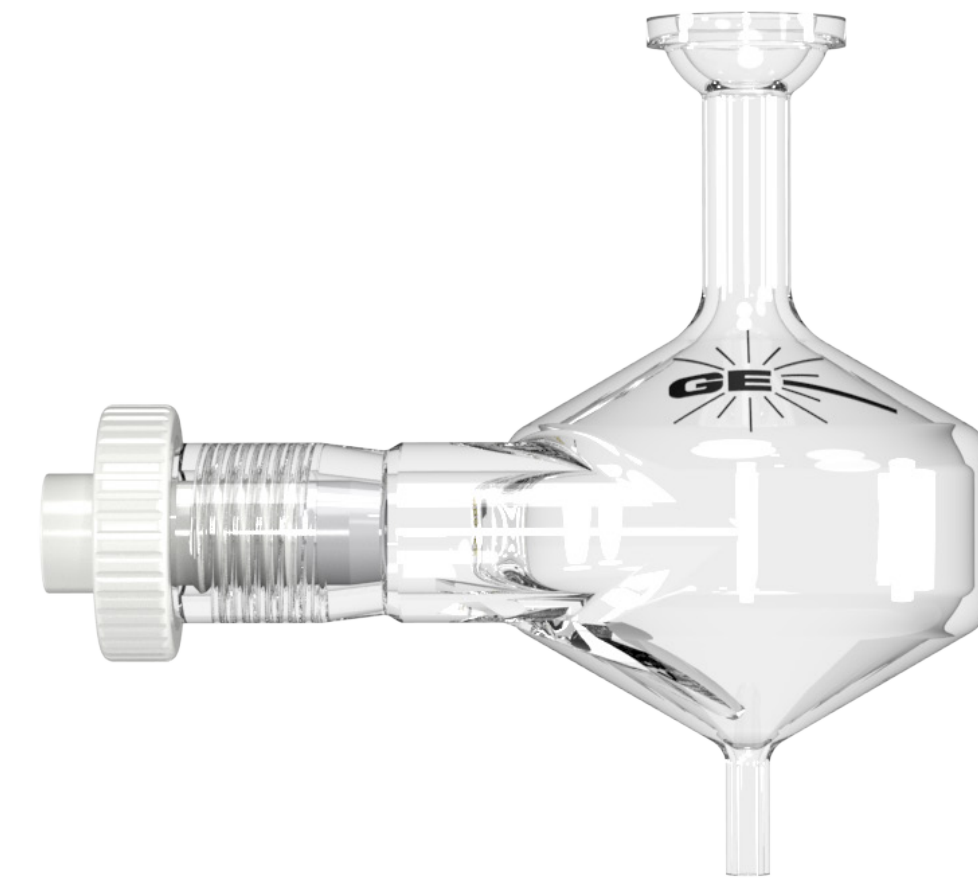

Support and Customer Service

- Over 40 years of expertise
- Fully equipped R&D ICP Laboratory
- Technical team
- Application notes
- Industry News
- Plasma Professor
- Catalogs
- Product flyers
- Website
- Product care advice
- Operating instructions
- Videos

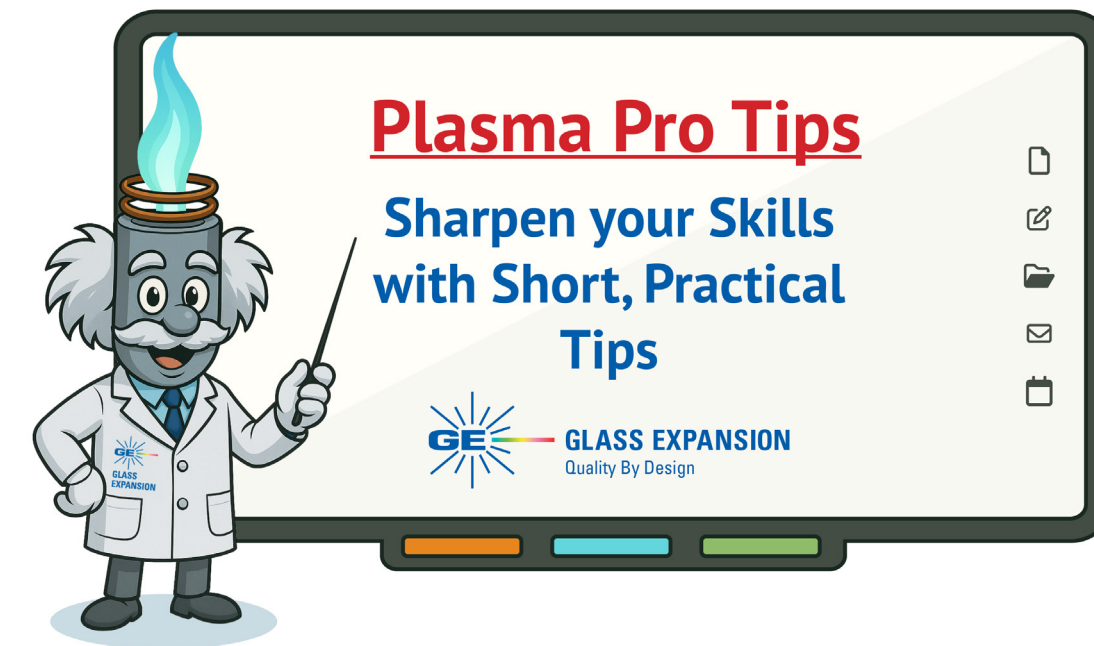

Plasma Professor



Flyers

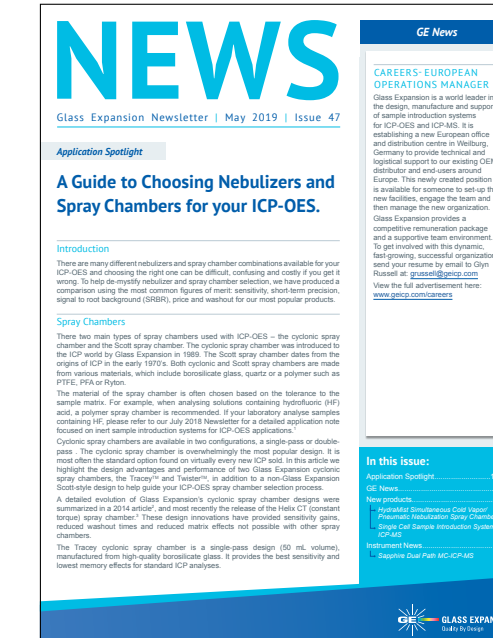

Newsletters



Instructions

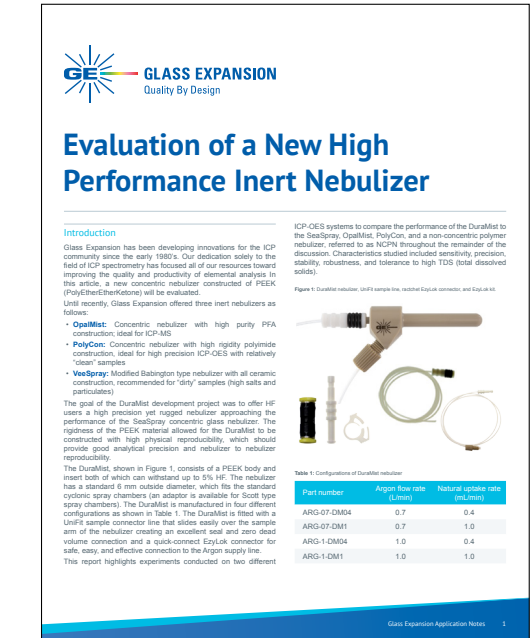

Application Notes

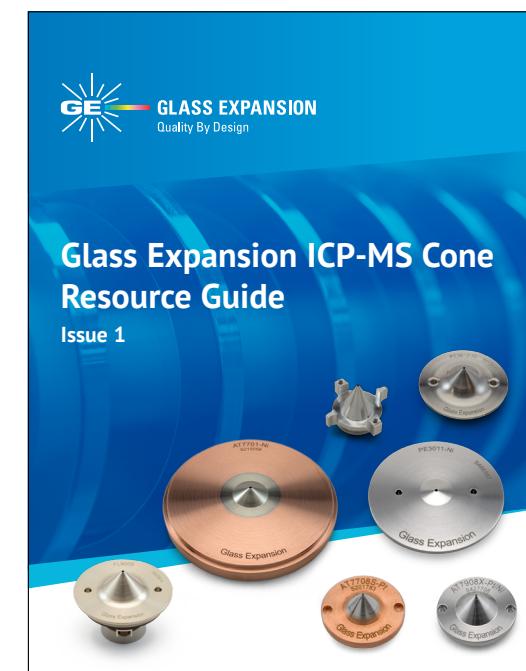
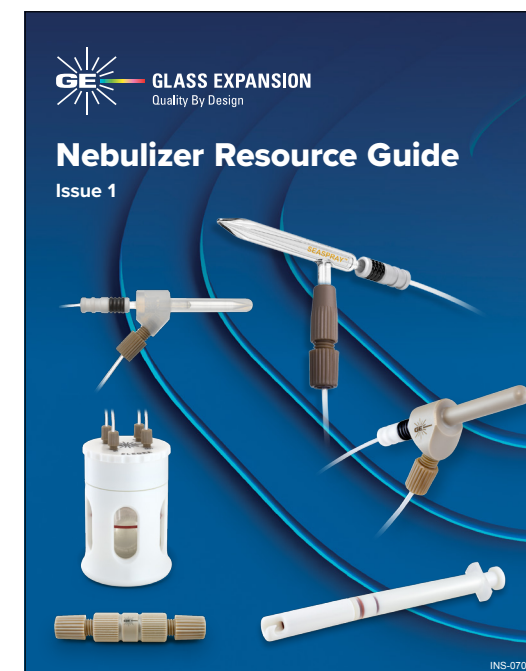

Catalogs

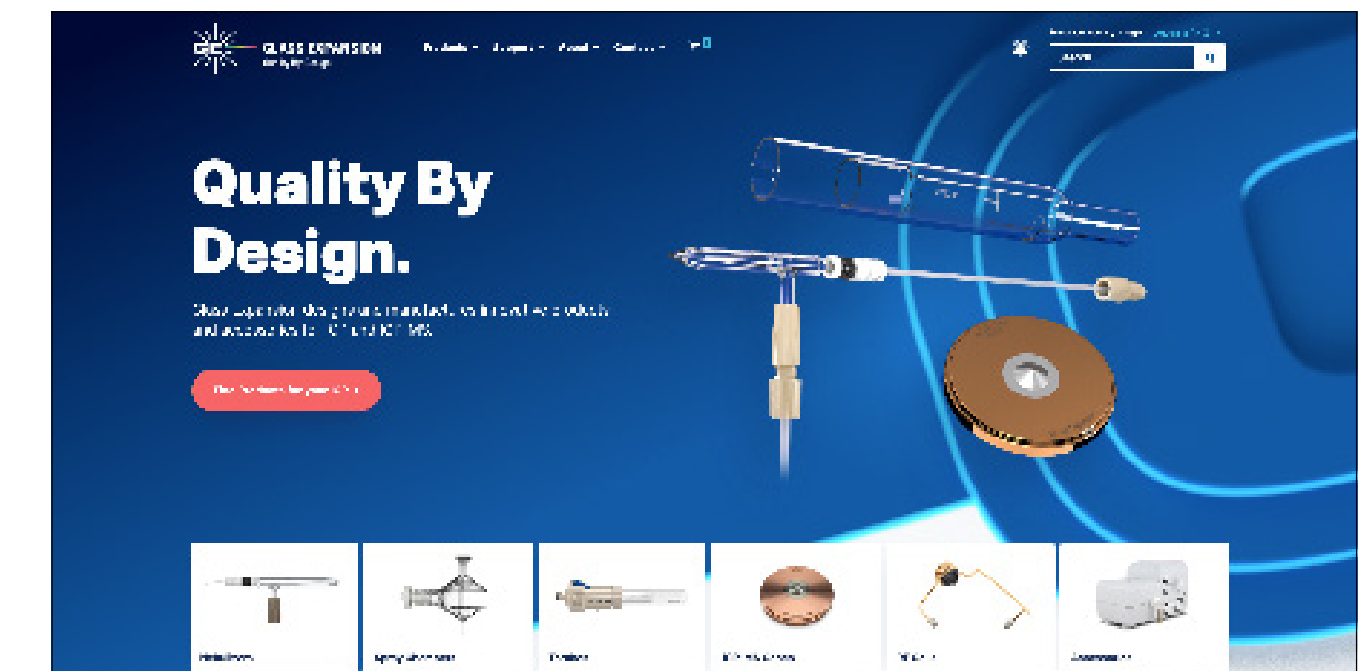

Website

Want a FREE review of your Sample Introduction System?

- ✓ Optimize your sample introduction system components
- ✓ Identify other performance enhancing accessories available for your ICP
- ✓ Discuss any sample introduction challenges
- ✓ Explore ways to reduce operating costs
- ✓ Obtain quotes

Contact by email: geusa@geicp.com

Thank You

Asia Pacific

6 Central Boulevard
Port Melbourne VIC 3207
Australia

Phone: +61 3 9320 1111
Email: enquiries@geicp.com

www.geicp.com

Americas

31 Jonathan Bourne Drive,
Unit 7, Pocasset, MA 02559
USA

Phone: 508 563 1800
Email: geusa@geicp.com

www.geicp.us

Europe

Friedenbachstrasse 9,
35781 Weilburg,
Germany

Phone: +49 6471 3778517
Email: gegmbh@geicp.com

www.geicp.de

